

LIFTWISE

Forklift Mounted Tire Handler FMTTH-1400

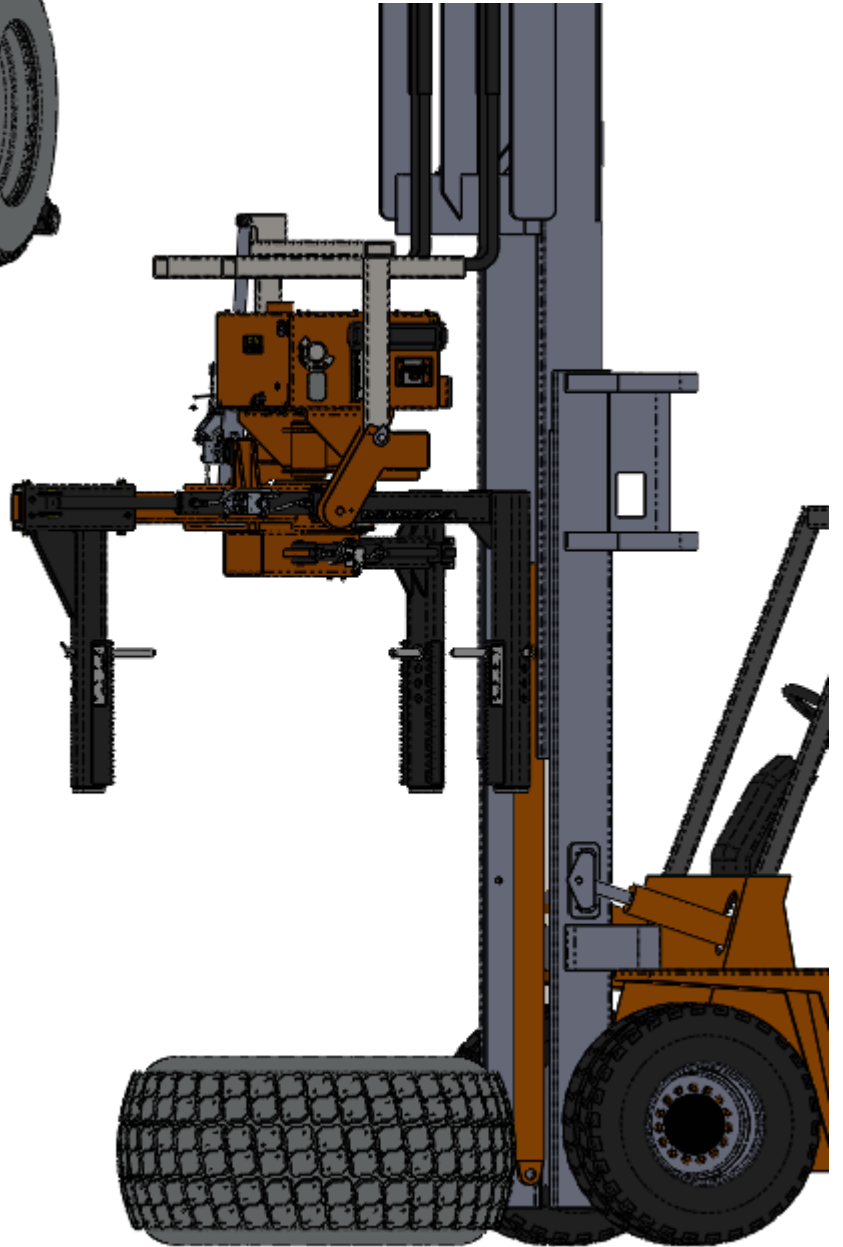
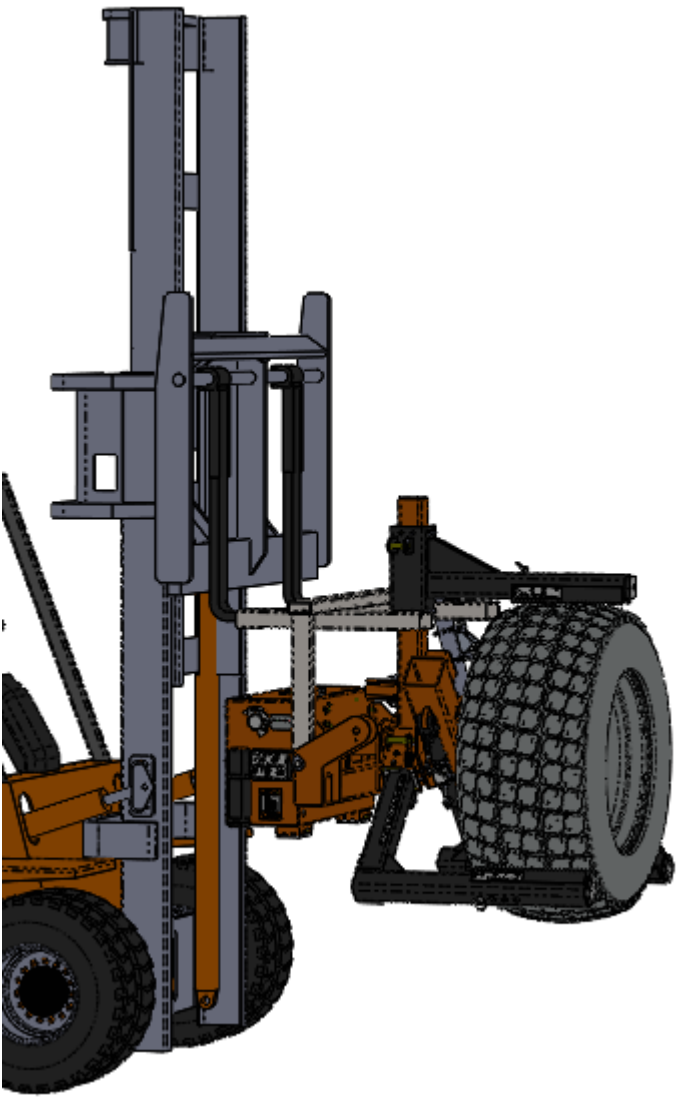

254-757-1177 | sales@lift-wise.com | lift-wise.com

SPECIFICATIONS

Load Capacity	1400 lb (635 kg)
Minimum Tire Diameter	30" (762 mm)
Maximum Tire Diameter	53" (1346 mm)
Maximum Tire Width	19" (483 mm)
Tilt from Horizontal to Vertical	90°
Rotation for Bolt Pattern Alignment	±25°
Weight	1300 lb (590 kg)
Time to Tilt from Horizontal to Vertical	18 seconds
Rotation from Neutral to 25°	7 seconds

OPTIONS

- Modified capacities and features to meet your applications

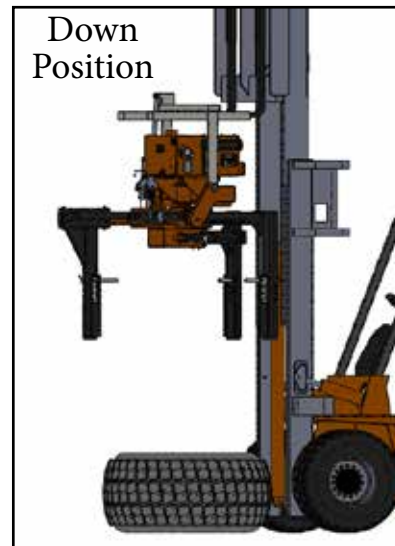
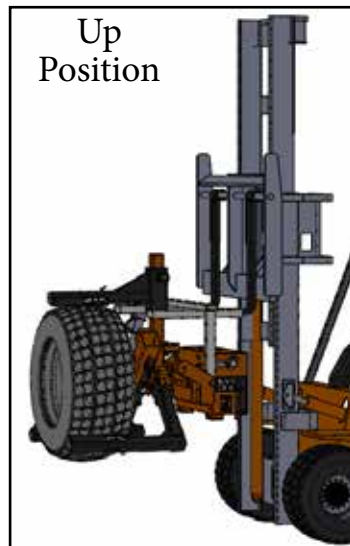

FEATURES

- 5 hydraulically powered functions
- Operated by radio remote
- Mounts to a forklift
- Adjustable pins to ensure correct tire orientation
- Lights indicating sufficient clamping pressure
- Onboard battery charger included
- 24V maintenance free battery system
- Self-contained hydraulic power unit (HPU)
- Operation, maintenance and parts manual included



CUSTOMIZED

MATERIAL HANDLING

SOLUTIONS

Material and specifications are subject to change without notice. Units in photos may include optional features. Contact a LiftWise representative for available options. LiftWise® and the LiftWise logo are registered trademarks of Diversified Product Development and may not be used without permission.

© 2020 Diversified Product Development All Rights Reserved.



254-757-1177 | sales@lift-wise.com | lift-wise.com